

UNION TEE - UT

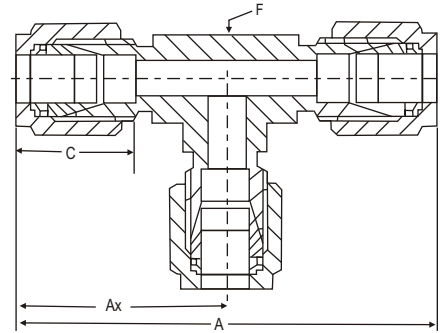

Dimensional Details :



Notes : Drawings are not to scale

Dimension, in.

Tube OD	Part Number	A	Ax	C	E	F
1/8	UT11	1.76	0.88	0.50	0.09	3/8
1/4	UT22	2.12	1.06	0.60	0.19	1/2
3/8	UT33	2.40	1.20	0.66	0.28	5/8
1/2	UT44	2.84	1.42	0.90	0.41	13/16
3/4	UT55	3.14	1.57	0.96	0.62	1 1/16
1	UT77	3.86	1.93	1.23	0.88	1 3/8

Dimension, mm.

Tube OD	Part Number	A	Ax	C	E	F in
6	UT6M6	53.9	27.0	15.3	4.8	1/2
8	UT8M8	59.7	29.9	16.2	6.4	5/8
10	UT10M10	63.0	31.5	17.2	7.9	11/16
12	UT12M12	72.0	36.0	22.8	9.5	13/16
16	UT16M16	77.6	38.8	24.4	12.7	1
18	UT18M18	79.6	39.8	24.4	15.1	1 1/16
20	UT20M20	89.3	44.6	26.0	15.9	1 3/8
22	UT22M22	89.3	44.6	26.0	18.3	1 3/8
25	UT25M25	98.3	49.1	31.3	21.8	1 3/8

UNION CROSS - UC



Dimensional Details :

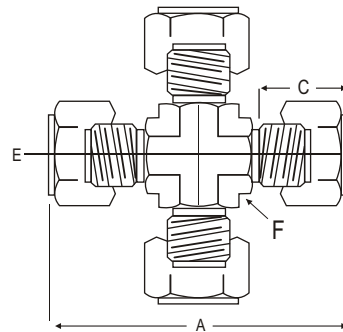

Notes : Drawings are not to scale

Dimension, in.

Tube OD	Part Number	A	C	E	F
1/8	UC11	1.76	0.50	0.09	3/8
1/4	UC22	2.12	0.60	0.19	1/2
3/8	UC33	2.40	0.66	0.28	5/8
1/2	UC44	2.84	0.90	0.41	13/16
3/4	UC55	3.14	0.96	0.62	1 1/16
1	UC77	3.86	1.23	0.88	1 3/8

Dimension, mm.

Tube OD	Part Number	A	C	E	F
6	UC6M6	53.9	15.3	4.8	1/2
8	UC8M8	59.7	16.2	6.4	5/8
10	UC10M10	67.0	17.2	7.9	13/16
12	UC12M12	72.0	22.8	9.5	13/16
16	UC16M16	74.0	24.4	12.7	15/16
18	UC18M18	76.6	24.4	15.1	1 1/16
20	UC20M20	89.3	26.0	15.9	1 3/8
25	UC25M25	98.3	31.3	21.8	1 3/8

Dimensions and specifications shown are approximate, may vary from time to time.

Note : A and C dimensions are typical finger-tight