

Special Features :

- Mineral Insulated with compact MgO Powder.
- Thermocouple with adjustable process connection for adjustable insertion length.
- Available in Various standard Sheath diameters and Sheath materials.
- Mineral insulation enables Thermocouples to be used at higher Temperatures.
- Standard followed in general IEC - 584.2 / ANSI MC - 96.1

Applications :

- Plastic Industries
- Moulding Machine
- Water & waste-water Treatment
- Power & Utilities

Specifications

STANDARD VERSION

No. Of Element	: Simplex
Element Type	: Type K (NiCr-Ni)
Accuracy	: Class '2' Tolerance as per IEC - 584.2 / ANSI MC - 96.1
Hot Junction Type	: Ungrounded Junction
Sheath Diameter	: 6.0mm
Sheath Material	: AISI 316 SS
Element Length	: 300mm
Cold End Termination	: Crimp-On Pot
Lead Wire Type	: PTFE / PTFE / SS Braided
Lead Wire Length	: 3000mm
Process Connection	: ½" NPT(M)

Dimensional Details :

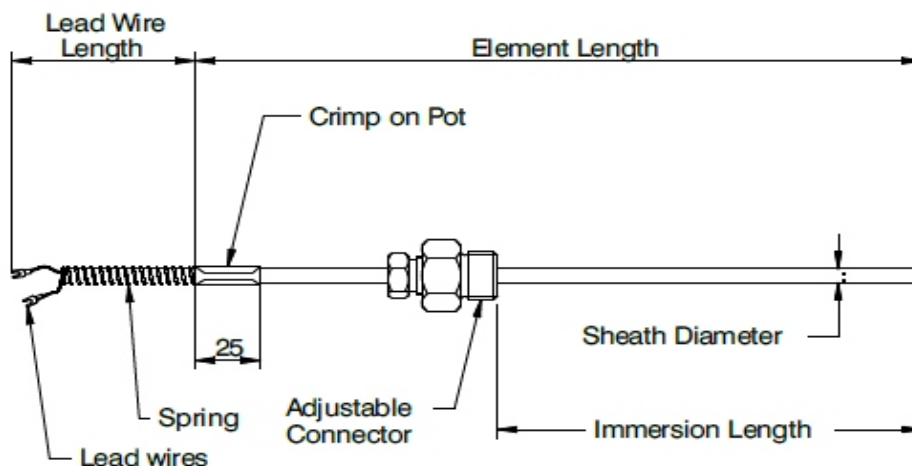

Note: Drawings are not to scale. All Dimensions are in mm.

SELECTION OF MODEL

(1) MODEL CODE

TC03

(2) NO OF ELEMENT

S

SIMPLEX	S
DUPLEX (Above Sheath Dia. 3mm)	D

(3) ELEMENT

K

Type K (NiCr-Ni)	K
Type J (Fe-CuNi)	J
Type N (NiCrSi-NiSi)	N
Type E (NiCr-CuNi)	E
Type T (Cu-CuNi)	T

(4) HOT JUNCTION TYPE

U

Grounded	G
Ungrounded	U

(5) SHEATH MATERIAL

S6

AISI 316 SS	S6
AISI 316L SS	S6L
AISI 310 SS	S10
INCONEL 600	IN

(6) SHEATH DIAMETER

6

3.0mm	3.0
4.5mm	4.5
6.0mm	6.0
8.0mm	8.0

(7) ELEMENT LENGTH

300mm

PLEASE SPECIFY IN mm

(8) LEAD WIRE LENGTH

3000mm

PLEASE SPECIFY IN mm

(9) LEAD WIRE TYPE

3

PTFE Insulated	1
PTFE / PTFE Insulated	2
PTFE / PTFE / SS Braided	3
FG / FG / SS Braided	4

(10) PROCESS CONNECTION TYPE

AD

Adjustable Connection	AD
Fixed connection	FX

(11) PROCESS CONNECTION

4NM

½" NPT(M)	4NM
½" BSP(M)	4BM
¾" NPT(M)	5NM
¾" BSP(M)	5BM

NOTE : Other connections are available on request.

SELECTION OF MODEL

(12) OPTIONS

Accuracy - Class "1" as per Standard	A1
Calibration Certificate	CC
SS Tag Plate	TS

Example	1	2	3	4	5	6	7	8	9
SELECTION OF MODEL	TC03	S	K	U	S6	6	300mm	3000mm	3

Example	10	11	12
SELECTION OF MODEL	AD	4NM	XX

XX

NESSTECH INC. INTERNATIONAL SALES DEPARTMENT

1-12-1 Akanehama, Narashino-shi, Chiba
275-0024, JAPAN

PHONE +81-47-453-1182
F A X +81-47-453-0727

■ NESSTECH INSTRUMENTS PVT. LTD (INDIA)

Survey No. 26/2, "G" Type, Global Industrial Park,
Near Nahuli Railwaycrossing, Village Valvada, Vapi,
Tal Umbergaon, Dist Valsad-396191, Gujrat
TEL: +91-260-299-6920

■ NESS TECHNOLOGY (M) SDN BHD (MALAYSIA)

No. 42A Jalan PUJ 3/8, Taman Puncak Jalil, Bandar Putra Permai,
43300 Seri Kembangan, Selangor
TEL: +603-8940-1134/8940-1059 FAX: +603-8999-4133